

Product data sheet: general air quality sensor

Range	N/A
Overload	N/A
Filtering	None
Expected life	5 years in non-corrosive atmosphere
Output signal	N/A
Temperature range	-20 to +50C
Pressure range	Withstands 10 atmospheres pressure
Pressure coefficient	TBA
T90 response time	N/A
Relative humidity range	15% - 90% non-condensing
Typical baseline offset (20°C)	25 nA
Typical baseline offset (40°C)	75 nA
Typical long term output drift	N/A
Interfacing requirements	Refer to datasheet
Repeatability	N/A
Output linearity	N/A
Temperature coefficient of response	TBA
Position sensitivity	None
Storage life	Two years at 20°C
Warranty	Two years in non-corrosive atmosphere
Weight	10g
Dimensions	40mm x 35mm x 9.5mm

SENSITIVITY DATA (1 mm aperture)	
Chemical	Sensitivity nA/ppm
Carbon monoxide	12
Methanol	20
Ethanol	20
Isopropanol	6
Formaldehyde	500
Acetaldehyde	5
SO ₂	10
H ₂	16
H ₂ S	100
Phenol	10
Dimethyl ether	Sensitive
Ethylene	Sensitive



Dart Marine Park, Totnes, Devon, TQ9 5AL, England
 Tel/Fax: +44 (0)1803 868698
 customer.service@dart-sensors.com | www.dart-sensors.com



Introduction

The Dart sensor for Air Quality (AQ) has been derived from the well established sensor for breath alcohol. A broad-based detector of general pollution, the air quality sensor has unlimited applications. It can be used as a general measure of air quality, or it can be used to monitor any of the individual gases to which it is sensitive, when cross-sensitivity is not likely to be a problem. It is an electrochemical sensor and is suitable for most ambient (-20°C to 50°C) uses. It has seven desirable design features.

Low cost

Simple design, ease of construction and few parts enable competitive pricing.

Broad range of gas sensitivities

It is sensitive to carbon monoxide, sulphur dioxide, hydrogen sulphide, alcohols, aldehydes, hydrogen, dimethyl ether and ethylene (see table). It is not sensitive to alkanes, ketones, aromatic hydrocarbons such as toluene, carbon dioxide or water vapour.

Long life

It uses well-established components from breath alcohol sensors whose accuracy, stability and durability have been demonstrated world-wide in 30 years' experience.

Fast response

A short, low-resistance diffusion pathway enables a rapid response to most gases: 90% response to isopropanol vapour at 15C (59F) in less than 20 seconds.

Low power requirement

Fuel cell principle means no power requirement, electricity being consumed only in signal processing and display, so a compact unit using small batteries is possible.

Stability

Exceptional stability allows very long intervals between calibration checks.

Withstands high pressures

Being of membrane-less construction, it contains no fragile components to rupture under wide pressure swings, and it has been shown to withstand ten atmospheres pressure.

How it works

The sensor chamber contains a conventional two-electrode fuel cell sensor. The working electrode works best with oxidisable gases, liberating electrons via the external circuit to the counter electrode, where they are consumed by the reduction of oxygen. The internal circuit is completed by ionic flow within the electrolyte.

Careful design enables the ebb and flow of the electrolyte, which expands and contracts with changes in ambient temperature and humidity, to take place without affecting the calibration.

Interfacing the Dart AQ sensor

The Dart AQ sensor will deliver a current with a linear relationship to active gases in air from zero to very high concentrations. This output will require amplification and, for increased accuracy, temperature compensation.

Amplification

The preferred method of amplification is to use an operational amplifier configured as a direct current-to-voltage amplifier. This will operate the sensor in its fastest possible mode. The gain is



Dart Marine Park, Totnes, Devon, TQ9 5AL, England
 Tel/Fax: +44 (0)1803 868698
 customer.service@dart-sensors.com | www.dart-sensors.com



determined by the value of the feedback resistor: with a value of 1000 ohms, a sensor output of (say) 5 microamps will appear as an amplifier output of 5 millivolts.

A sensor left on open circuit will gradually develop an offset. No harm will be done but it may take some time to discharge on reconnection. For this reason, the output terminals are normally short-circuited during storage. There should be no significant permanent offset. In use, to avoid the build-up of an offset when the amplifier is switched off, a low value resistor (typically 620 ohms) can be placed permanently across the terminals. Alternatively, a good solution is to keep the amplifier permanently powered.

A typical circuit is shown below.

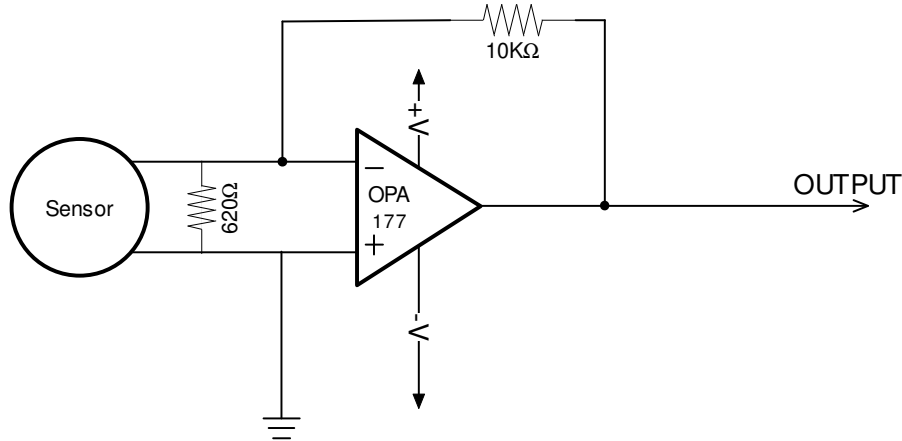

Note that this circuit uses a dual rail power supply which gives the best results. We recommend the Burr-Brown OPA177 op-amp in this and similar circuits. A good low power alternative is the OPA 241 which is slightly noisier. Both have very low intrinsic offsets but for exceptionally sensitive work, they have the facility for incorporating an offset trimmer to tune out residual offset.

We have carried out studies on single rail supplies using dedicated op-amps such as the OP90, and recommend against their use. For 3V supplies we recommend the generation of a negative supply by means of an IC such as the ICL 7660.

Temperature compensation

For most applications of broad-band AQ detection, the question of the temperature coefficient of output might not be important. But if you are using the sensor to measure a particular component where it is likely to be the only species detected, and you want to achieve a greater accuracy, then you should apply a temperature-dependent compensation. A standard negative-coefficient thermistor will provide a suitable signal.

There are two components to the temperature-dependent behaviour:

1. The rate of diffusion of the gas increases with temperature.
2. Particularly at low temperatures, the efficiency of the electrocatalyst is impaired and this becomes the rate-determining factor.

By way of example, here are typical data for the temperature effect on sensitivity to carbon monoxide (2 mm aperture).

At -10°C	24 nA/ppm CO
At 25°C	31 nA/ppm CO
At 50°C	34 nA/ppm CO



Dart Marine Park, Totnes, Devon, TQ9 5AL, England
 Tel/Fax: +44 (0)1803 868698
 customer.service@dart-sensors.com | www.dart-sensors.com



Configuration

The sensor housing is 35 mm square by 9.5 mm depth. It has four securing holes at the corners, and there is a recess on the face which will receive a 1.5 mm X 31 mm ID O-ring, to enable an airtight seal to be made to your instrument body. This will help prevent polluted air from getting behind the sensor, and subsequently re-emerging to give a false elevation of the reading.

Sensitivity

The sensitivity is determined principally by the diameter of the access aperture on the face of the sensor: the bigger the hole, the more gas can diffuse into the sensor and hence the bigger the signal. The standard arrangement (and smallest practical aperture) is a single central hole of 1 mm diameter, but this can be altered to suit customer requirements. The aperture should be chosen to give an adequate signal-to-noise ratio, but excessive amounts of gas sample should be avoided to prevent problems with non-linearity, slowness of clean-up etc.

The air quality sensor is intrinsically sensitive in varying degrees to various gases and vapours as listed on page 1. Gases and vapours to which the sensor is not inherently sensitive include: saturated and aromatic hydrocarbons such as toluene; acetone, ammonia, nitrogen, oxygen, chlorine, water vapour, and carbon dioxide.

Further information

Dart Sensors gives full technical support to users of its products. If you have any queries which have not been addressed above please contact us at:

customer.service@dart-sensors.com.



Dart Marine Park, Totnes, Devon, TQ9 5AL, England
Tel/Fax: +44 (0)1803 868698
customer.service@dart-sensors.com | www.dart-sensors.com

